

(26-01-94 GB3)

I N S T R U C T I O N
M I C R O C E N T R I F U G E
T Y P E 1 5 7 M P

In order to utilize the MICROCENTRIFUGE type 157.MP to the best possible extent, it is absolutely essential that these instructions be read before taking the centrifuge into use.

After the actual instructions for use, guidance is provided in the rectification of minor operational failures together with instructions for the despatch (transport) of the centrifuge.

If the centrifuge cannot be made to function in the normal manner without dismantling, please contact us or our agents.

If the centrifuge is to be shipped or transported to another place of use, or returned for service (repair), it is essential that the packing instructions are followed carefully.

If the transport security is not carried out as described, the motor and rotor system can give rise to internal damage to the centrifuge.

We cannot be held responsible for any failure or damage arising during transport (despatch) as a result of poor packing and inadequate transport security not conforming with section 6.

The factory guarantee will no longer apply if, during the guarantee period, the centrifuge is interfered with (dismantled) without our express consent or the consent of our agents.

TABLE OF CONTENTS		PAGE
GENERAL		1
TECHNICAL DATA		3
STANDARD DELIVERY INCLUDES		3
GENERAL		4
REMOVAL OF TRANSPORT SECURITY SCREWS		4
CHANGING THE ROTOR		5
TECHNICAL INFORMATIONS CONCERNING CENTRIFUGE		5
PROGRAMMING		6
ERROR MESSAGES		7
1.0.0 OPERATIONAL FAILURES		9
2.0.0 TESTING THE CENTRIFUGE'S FUNCTIONS		10
6.0.0 TRANSPORT AND PACKING		10+16
7.0.0 SERVICE PLAN		11
SPAREPARTS		12
SAFETY REGULATIONS FOR USE OF CENTRIFUGES		13
CONDITIONS OF GUARANTEE		15
DRAWINGS		16+17
ACCESORIES AND ROTORS		18+19
INSERTS FOR ROTORS		20

T E C H N I C A L D A T A

99 SELECTION-FREE PROGRAMMES WITH BACK-UP

MAX. SPEED: 25.000 rpm.

G-VALUES: 100 - 30.000 x g stepless.

MAINS SUPPLY: 230 volt AC +- 10 %.

POWER CONSUMPTION: 10/400 watt.

ELECTRONIC TIMER: 10 sek. - 99 min.
and constant run.

CABINET: 6 mm aluminium.

WEIGHT: Ca. 14 kg.

H x B x D: 200 mm x 260 mm x 385 mm.

Standard delivery includes:

1 mains lead (14)

1 three-hole key (154.08.20) for changing rotor

1 hexagon key (154.02.50) for emergency opening of lid

GENERAL

The centrifuge must be connected to the protective earth of the mains supply

Check the centrifuge for possible transport damage.

The red transport securing screw in the bottom of the centrifuge must be removed first, after which the three yellow screws can be removed (see fig.12).

The centrifuge must only be connected to 230V AC, and is protected with two 3,15 amp. FF fuses. (see fig. 2).

The mains connection (14), the main switch (13) and the fuses (15) are located on the back of the cabinet.

The cover is always locked upon receipt, and no attempt must be made to open it by force. In the event of an emergency, it can be opened with the hexagon key 154.02.50 provided.

The lid can always be opened when the centrifuge is connected to the mains (14) and the main switch (13) is on.

Check: Light in the LCD display.

If, upon receipt, the centrifuge is not provided with a rotor, mount the rotor as described under "Changing the rotor".

The centrifuge is now ready for use.

The centrifuge is provided with a special suspension for the motor and rotor spindle, and thus it is only necessary to balance the inserts visually.

In the event of **excessive** unbalance or a strong shock, an unbalance switch will cut off the motor and the centrifuge is braked with max. effect.

If, for some reason or another, the centrifuge stops before the "clock" has shown 00.00 (power failure - unbalance - shock etc.), an error message will be shown on the LCD display as an indication that the samples have not been centrifuged for the programmed time.

Error messages can be annulled by pressing |ENTER| (possibly several times).

See section concerning error messages.

A current limiter built into the centrifuge ensures that the motor is not ruined, even in the event of gross misuses.

CHANGING THE ROTOR

When changing the rotor, the accompanying rotor key 154.08.20. must be used.

The rotor shaft is provided with a right-handed thread.
The nut must be turned anti-clockwise until the rotor has been drawn completely free of the flange (1). (see fig.1).

Before fitting a new rotor, check that the rotor and the flange are clean.

When fitting the rotor, the pins (12) in the flange (1) must engage the holes in the rotor before the thread can take hold. The nut must be turned clockwise until it stops (tighten well).

The centrifuge is ready to start, and the built-in rotor-code reader ensures the correct g-value in accordance with the rotor's data.

TECHNICAL INFORMATIONS CONCERNING TYPE 157.MP

G - values from 100 - 20,000 g, depending of the rotor's data, are coded-in with the |G| key + number keys. G - values in excess of those permissible for a given rotor will result in instant stop immediately after start.

Acceleration and braking times are coded-in with |Acc| + |0| keys. Each time the |0| key is pressed, the display will change between HARD - NORMAL and SOFT acceleration. The acceleration and braking time are the same, i.e. the acceleration time for a given rotor correspond to the braking time.

A given program is selected with |Prog| + number keys. Here it is possible to code-in selective programs from no. 0 - 99, all with back-up, and thus a program code-in will always be retained.

It is possible to leaf through all the program numbers by holding the |Prog| key pressed. The centrifuge will always start up in the last program used. By pressing the |Prog| key during operation, it is possible to display all the informations concerning the program in progress. The program information is displayed for 3 seconds, after which the current values return automatically. During operation, it is not possible to change the incoded values or to change to another program. However, an exeption here is program no. "0", in that here it is possible to code-in new values for the centrifuging in progress.

The centrifuging time is entered in minutes an seconds with the |Time| key + number keys, and can be read from the display. Centrifuging times from 5 secs. to 99 mins. 59 secs. may be coded-in. When entering times less than 1 minute, first press |0| + |0| followed by the desired number of seconds.

When entering 99,99 mins. the display will show ">>>>" and the centrifuge can be operated in unlimited periods. (To stop the centrifuge, press |STOP| button).

The time is calculated from start (incl. acceleration) to the commencement of the braking down.

Press |START|.

After start, the display will show the remaining centrifuging time together with the current g-value.

Check that the coded-in g - value is reached.

When the time has expired, the centrifuge will be braked automatically, and the lid may be opened when the display changes from **PROGRAM RUNNING** to **PROGRAM** .

If the centrifuge is required to be stopped before the expiry of the time coded-in, press the |STOP| key.

A coded-in program sequence can be repeated by pressing |START|.

I M P O R T A N T : The cooling holes in the lid of the centrifuge must not be covered, the reason being that this will give rise to unnecessary heating of samples.

In the event of mains voltage failure or a functional failure, the lid can always be opened with the help of the accompanying hexagonal key 154.02.50, which is inserted in the lock through the hole (11) in the right-hand side of the cabinet.

The key must be turned clockwise

PROGRAMMING OF THE CENTRIFUGE TYPE 157.MP

In program number 5, the following parameters are required to be coded-in:

g - value : 17,000
Time : 57 mins. 30 secs.
Acceleration : Hard

EXAMPLE OF CODING - IN

Program 5 : Press |Prog| |5| |Enter| after which the display shows PROGRAM 5
g - value : Press |G| |1| |7| |0| |0| |0| |Enter|
Time : Press |Time| |5| |7| |3| |0| |Enter|
Acceleration : Press |Acc| |+| |0| (possibly several times) until the display shows HARD at new ACC |Enter|

Errors and failures in the operation of the centrifuge are registered and handled by its microprocessor and written out in the display. The following is a complete list of all the error messages and instructions which can appear in the display. A brief explanation is provided against each error message or instruction.

Under certain circumstances, the centrifuge can display errors without any apparent reason. Therefore, always cancel an error message by pressing `|ENTER|` and restart the centrifuge. If several errors arise in succession, these are displayed each time `|Enter|` is pressed.

If errors continue to be displayed, contact us or our agent.

PROGRAMMED G-VALUE
ABOVE ROTOR LIMIT !
---AWAIT rotor stop
* ENTER to continue

The programmed G-value is higher than that allowed for the relevant rotor.
Check max G-value on the rotor or better in the rotor list in instruction for use.

ROTOR NOT IN TABLE !
Call O.Dich service
department.
* ENTER to continue

No rotor code on the mounted rotor, or the rotor mounted is of newly-developed type which is not coded in the centrifuge's memory.

R O T O R E R R O R
Wait until rotor
stopped
* ENTER to continue

Defect or unclear rotorcode.
Error in rotor code reader or its circuit.
If displayed after replacement of the motor, the reason could be that the direction of rotation is incorrect

* U N B A L A N C E
Wait until rotor
stopped
* Enter to continue

Possible reasons: Rotor incorrectly secured.
Foreign bodies between rotor and flange
Samples placed unsymmetrical in rotor.
Faulty unbalance switch.

CHANGE OF RUNNING
SET VALUES :
USE PROGRAM 0
* ENTER to continue

If one of the key's `|G|` `|Time|` or `|Acc|` are activated during centrifuging. Use program "0" if the parameters are desired to be changed during centrifuging.

* POWER FAILURE ***
Wait until rotor
stopped
* ENTER to continue

Power failure or too low voltage during a program sequence.

BATTERY BACKUP ERROR
Call O.DICH service
department
* ENTER to continue

Failure in the battery back-up.

* LID UNLOCKED ****
(start pressed or
rotor running)
* ENTER to continue

The start button has been activated with open lid, or with lid partly closed, especially on type 157.MP.RF. Press at point (T) so that button (D) springs out.

OPERATIONAL FAILURES

1.0.0 Testing and fault-finding without dismantling.

.1.0 There is no text in the LCD display.
Check the following points:

- .1 Mains power supply 230 volts +/- 10% 50 Hz.
- .2 The mains cable (14) must be pressed completely into the centrifuge's supply socket. (see fig. 2).
- .3 The main switch (13) is on (text in display).
- .4 The two 3,15 Amp. FF fuses (15) has not blown.
- .5 The power cable (14) is checked for intermittent failure, e.g. when the cable is moved (bent at the plugs).

1.2.0 There is text in display, but the centrifuge does not function in the normal manner.

Check the following points:

- .1 The electronic clock must be set at a minimum of 10 secs.

The centrifuge will not start if the clock shows 00.00

- .2 The lid must be completely closed.
- .3 Both microswitches at (C) must be activated when the cover is opened and closed (can be heard).
- .4 Immediately after the main switch (13) has been switched on and there is text in the display, the lid must be able to be opened.

N.B! The lid cannot be opened when the display shows LID LOCKED.

After two minutes stand still (without operation), all unnecessary current consumption is cut off and the lid is locked.

Press |Enter| possibly also |STOP| and open the lid.

The lid can always be opened with the hexagonal key 154.02.50, which is inserted in the hole (11) in the right hand side of the centrifuge.

The key must be turned clockwise.

- .5 When the mains voltage is switched off, the lid must be locked.

2.0.0 TESTING OF THE CENTRIFUGE'S FUNCTIONS

1.0 Unbalance switch

- .1 The unbalance switch must be activated if the centrifuge, with slowly rotating rotor, tilts approx. 45 deg. to the right and the display must show **UNBALANCE** .
- .2 It must always be possible to annul the error message by pressing |ENTER|. If several errors have arisen in succession, |ENTER| may have been pressed several times.

2.2.0 Lid-locking system.

- .1 The locking pawls must work freely when the right microswitch is activated with a ball pen and the like through the right-hand locking pawl hole (C). (see fig. 1).
- .2 The lock system can be tested by letting the centrifuge stand idle with closed lid for approx. 2,5 minutes. The lid must then be locked and the LCD display must show **LID LOCKED**.

To open the lid, press |ENTER| possibly |ENTER| + |STOP| .

The following instructions must be observed very closely in order to avoid damage to the centrifuge during transport.

6.0.0 The centrifuge motor and rotor system **must** be secured with the one red and the three yellow screws. (see fig.12).

- .1 The centrifuge is placed bottom upwards.
- .2 Screw the three **yellow screws** with washers (A) into the base plate as shown (fig. 12).
- .3 The system is finally secured with the **red** screw and the associated bush (B).
- .4 The rotor **must not** be mounted during transport. This is to be wrapped carefully in paper or the like and then placed with the underside upwards in the rotor chamber.

6.1.0 PACKING

- .1 Protect the centrifuge with plastic foil.
- .2 Place the centrifuge in a special wooden crate and secure it firmly with four angle blocks (C) and (D) of plastic (see fig. 13).
- .3 Ensure that the centrifuge is held firmly in all directions before nailing on the lid of crate. (E)
- .4 Bind the crate with at least two steel or plastic bands.

7.0.0 SERVICE PLAN FOR MICROCENTRIFUGE TYPE 157.MP AND 157.MP.RF

- 1.0 All centrifuges once a year: points 7.0.1 - 7.0.9
Can be carried out without dismanteling the centrifuge.
- .1 Check the lid for cracks, crackling and the like, particularly around the screw holes.
 - .2 Check the funktions of the microswitches
point 2.2.0 - 2.2.2.
 - .3 Check the lock hooks for breakage and overload.
 - .4 Check the working ability of the locking pawls - must work freely when the right microswitch is influenced with a ballpen and the like through the righthand locking pawl hole (C). (see fig. 1).
 - .5 Check the centrifuge rotor for cracks and impact marks.
Examine particularly whether the fixing surface is free of foreign bodies and impact marks. The centre screw must be able to be turned with the fingers.
 - .6 Check the rotor flange for impurities, crooked pins and marks.
 - .7 Test the function of the unbalance switch
see 2.1.0 - 2.1.2.
 - .8 Test all of the electrical functions and examine whether the centrifuge's plugs are of the correct type with earth.
Check with an ohmmeter whether there is connection from the earth pin of the mains cable to frame.
 - .9 Check that the fuses at the rear of the centrifuge are of the right type: FF 3,15 Amp superfast.

7.2.0 157.MP.RF. ONLY

- .1 Clean the cooling unit with a vacuum cleaner or compressed air.
- .2 Inspect the spindle bellows (157.19.24) and lid gasket (154.19.23) for cracks and the like.

7.3.0 The following points apply **once a year** for centrifuges with a daily motor operation time of **more than four hours**.

For centrifuges with motor operation time of **less** than four hours daily, only **every third year** or if one of the points 7.0.1 - 7.0.8

- .1 Dismantle the cabinet - see servicemanual.
- .2 Change the drive belt see servicemanual points 4.8.0 - 4.8.5.
- .3 With belt removed, check the spindle bearings - must run easily without noise when rotated with fingers.
- .4 The opto-tacho unit is to be brushed or blown free of dust - can also be cleaned with a pipe cleaner in the notch.
- .5 Check the motor brushes **must be changed if less than 9 mm length.**

S P A R E P A R T S

- 154.00.23 Unbalance switch.
- 154.01.14 Plastic foot for base plate.
- 154.02.16 Rotor-spindle complete.
- 154.02.19 Guide pin.
- 154.02.26 Drive belt.
- 154.02.50 Hexagonal key for emergency opening.
- 154.03.03 Cover.
- 154.03.09 Lock-pin.
- 154.04.01 Motor complete.
- 154.04.02 Brush holder cap.
- 154.04.03 1 set brushes (state cent. serial nbr).
- 154.08.20 Rotor key.
- 154.10.01 Fuse 3,15 Amp FF.
- 154.10.02 Microswitch.
- 154.10.14 Locking magnet coil.
- 154.10.16 Mains transformer.
- 154.10.18 Mains lead.
- 154.10.21 Opto-tacho component.
- 154.19.23 Rubber packing for lid.
- 155.01.20 Vibration damper.
- 157.00.13 Rotor shaft system complete.
- 157.02.00 Motor / Rotor system complete.
- 157.07.23 Protective sheet for power-PCB.
- 157.11.01 Frontplate ex. LCD-display.
- 157.11.02 LCD Display.
- 157.12.06 Mains switch incl hum eliminator.
- 157.12.07 Relay for compressor PCB.
- 157.12.19 Rotorcodereader.
- 157.12.21 Temperaturefeeler complete.
- 157.12.22 Rotorcodereader complete.
- 157.12.23 Compressor-PCB complete.
- 157.12.24 Opto-tacho unit complete incl. leads.
- 157.12.25 Control-PCB type MPRF.
- 157.12.26 Control-PCB type MP.
- 157.12.27 Power-PCB.
- 157.19.24 1 set packing for spindle.

SAFETY REGULATIONS FOR USE OF CENTRIFUGES

INSTRUCTIONS

A centrifuge must only be operated by personnel who are thoroughly trained in its use, and instructions must be available containing prescribed max. revolutions or g-values. The supplier's instructions for use and maintenance must be adhered to.

BEFORE STARTING

Check that the rotor's securing nut is sufficiently tight.

Inflammable liquids give off vapours which can be explosive, and must not be centrifuged without special precautions (possibly test tubes with screw caps). Corresponding precautions must also apply for the centrifuging of acids. Never use centrifuge glasses which are cracked or chipped.

The samples must be equally and symmetrically distributed in the centrifuge rotor. When rubber inserts are used, it must be checked that there is one and only one inserts in each hole. When using adaptors, these must in pairs of the same type and be placed symmetrically in the rotor.

Never set the centrifuge to run at a higher rpm or g-value than that stated on the rotor being used.

AFTER STARTING

If the centrifuge vibrates excessively, creates noise or shows other signs of irregularities, the centrifuge must be stopped immediately and the cause must be found. If the cause is not found, the centrifuge must be returned for service immediately.

NEVER USE A DEFECTIVE CENTRIFUGE!

Rotor buckets, glass holders, rotor and rotor-chamber must be washed and disinfected immediately if there is splintered glass or spilt liquid. In the event of visible pollution of the centrifuge with blood, tissue fluids or the like, disinfection must be carried out immediately.

CLEANING AND MAINTENANCE

With daily use: At least once every week.

With less frequent use: At least once every month.

When used for the centrifuging of corrosive liquids, the centrifuge must be cleaned immediately after use. Before cleaning/maintenance, remove the plug from the supply socket. Disinfection is to be carried out either as hot disinfection or as chemical disinfection.

In order to avoid chemical disinfection agents, it is recommended to carry out hot disinfection in a dish-washing machine. This is carried out as follows:

- Remove the rotor and holders and place them in the washing machine.
- Clean the centrifuge's rotor chamber using one of the disinfection agents mentioned below.

With hot disinfection, the items being disinfected must reach a temperature of at least 80°C and a maximum of 90°C (most plastic materials cannot tolerate temperatures above 90°C, and it is recommended that plastic items are chemically disinfected).

Where hot disinfection is inadequate or impossible, a chemical disinfection must be carried out as follows:

- Rotor, buckets and adaptors are to be removed and placed in a bath so that they are completely submerged. They must remain in the bath for a minimum of 1 hour.
- The centrifuge's rotor-chamber must be cleaned with one of the chemical disinfection agents mentioned below.

It is recommended that in the event of the risk of infection with virus, (AIDS, hepatitis, or the like), 3% Korsolin must be used (see medicament recommendations), and gloves must be used in the event of direct contact.

In the event of the risk of infection from bacteria, 2% Bacillotox can be used. As an alternative, 62% hospital spirit can be used.

After cleaning, the centre-screw for the rotor **must** be lubricated with a small amount of thin oil.

ALWAYS REMEMBER TO TIGHTEN THE ROTOR SECURELY. (If the centrifuge is to be inspected or serviced, the rotor must not be mounted).

NOTE!

Before service/repair/maintenance of the centrifuge that is to be undertaken by OLE DICH INSTRUMENTMAKERS APS or supplier, it must be cleaned and disinfected in accordance with the instructions above. This cleaning and disinfection is the user's responsibility.

In all correspondence with OLE DICH concerning repair, reference must be made to the centrifuge type and its serial number.

CONDITIONS OF GUARANTEE

Should this apparatus be found to have defects or deficiencies, use can be made of the guarantee as stipulated in this written guarantee.
The guarantee does not restrict your rights with respect to prevailing law.

PERIOD OF GUARANTEE

This guarantee is valid for 12 months from the documented date of purchase from us or our agents.

EXTENT OF GUARANTEE

Our service department or our agents undertake at our expense to rectify production or material failures which can be ascertained in normal use of the apparatus.

When possible failures are to be rectified, the purchaser must at his own expense and risk deliver the apparatus with reference to its date of purchase and serial number to our service department or to the agent from whom the product was purchased. If the apparatus is to be dispatched or transported for service (repair), the packaging instructions must be closely adhered to. If the transport safety precautions and/or the packing are not in accordance with the instructions, the motor/rotor system will suffer damage. Damages and defects which arise during transport (dispatch) as a result of incorrect or inadequate packing etc. are not covered by the guarantee.

Repairs effected under the guarantee will be carried out free of charge. The repair will not extend nor give rise to a new start date for the period of the guarantee. Parts which are replaced will become our property. After repair, the apparatus will be returned at our expense.

THE GUARANTEE DOES NOT COVER

Defects or damages arising directly or indirectly as a result of incorrect operation or use, or failure to allow us or our agents to undertake an annual inspection of the apparatus as prescribed in the instructions for use (the safety inspection is carried out at the customer's expense).

Defects or damages arising as a result of the ingress of water, incorrect installation or connection, or as the result of fire, accident, lightning, extraordinary voltage variations or other electrical disturbances such as, e.g. defective fuses in the electrical power supply installations, and repair or other maintenance not carried out by us or our agent, without our written consent.

DATE OF PURCHASE:

STAMP:

INVOICE NO.

TYPE/SERIAL NO.

AGENT:

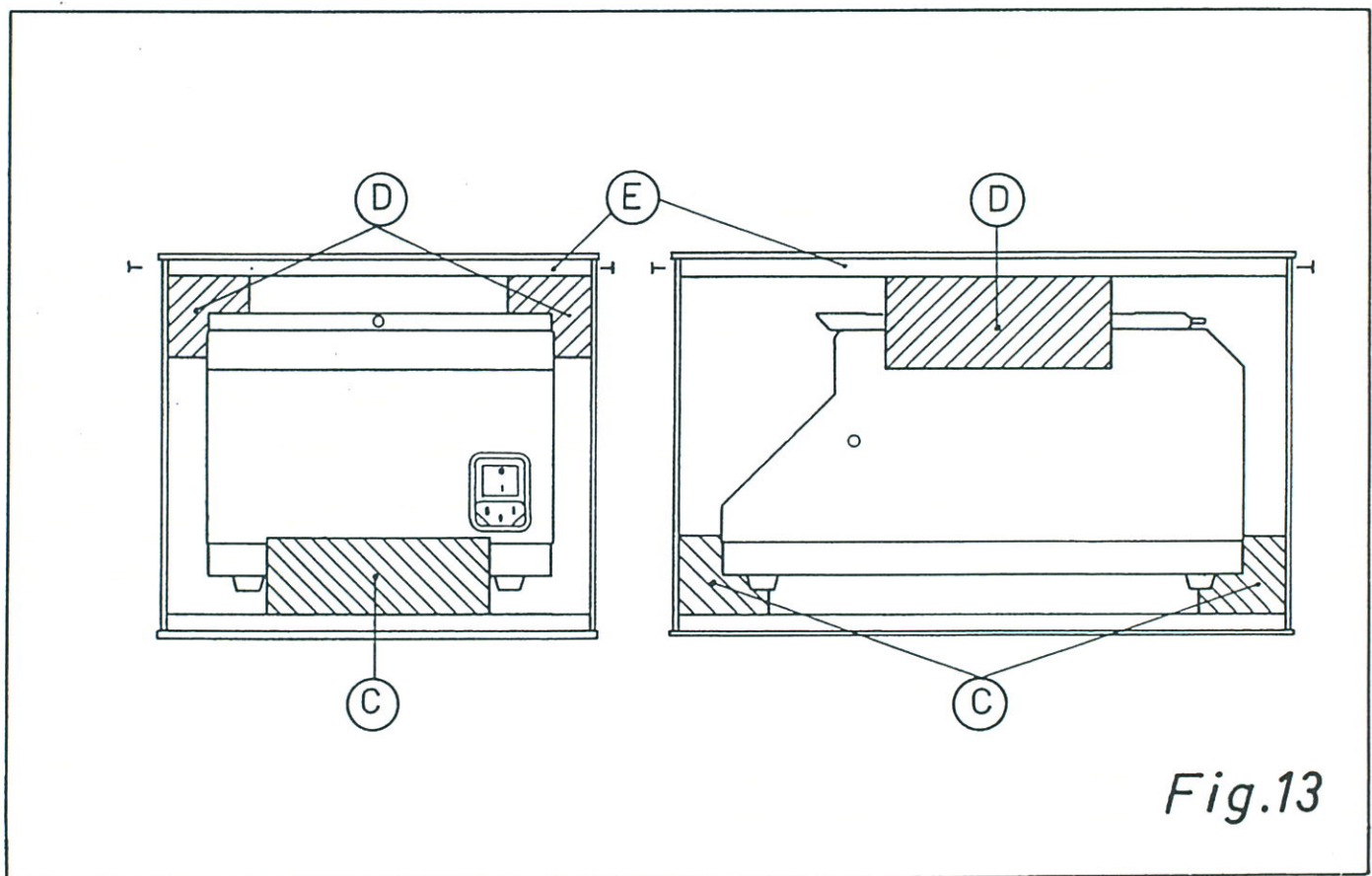
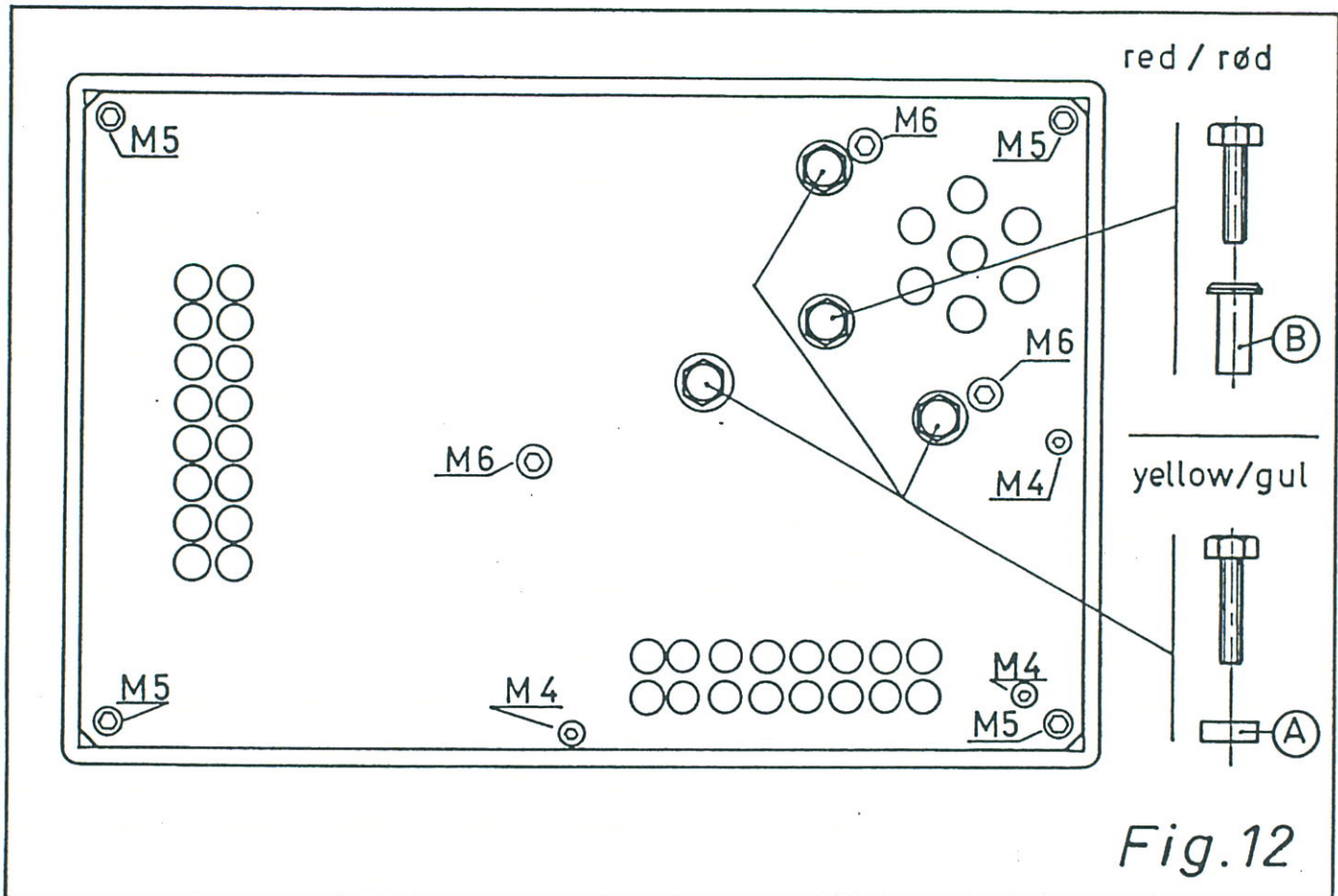

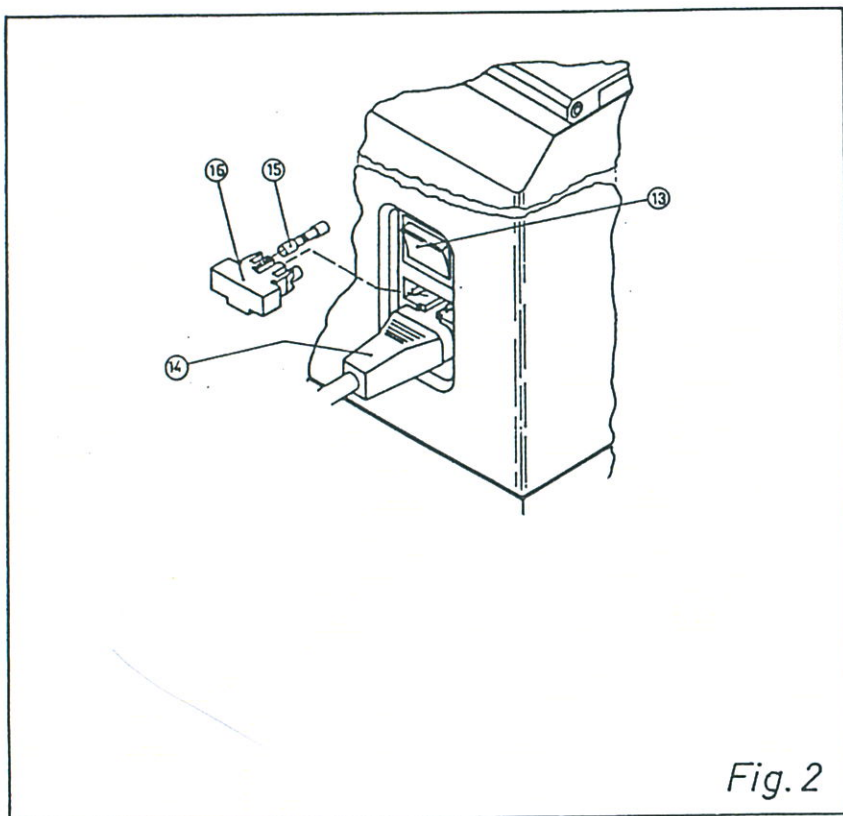
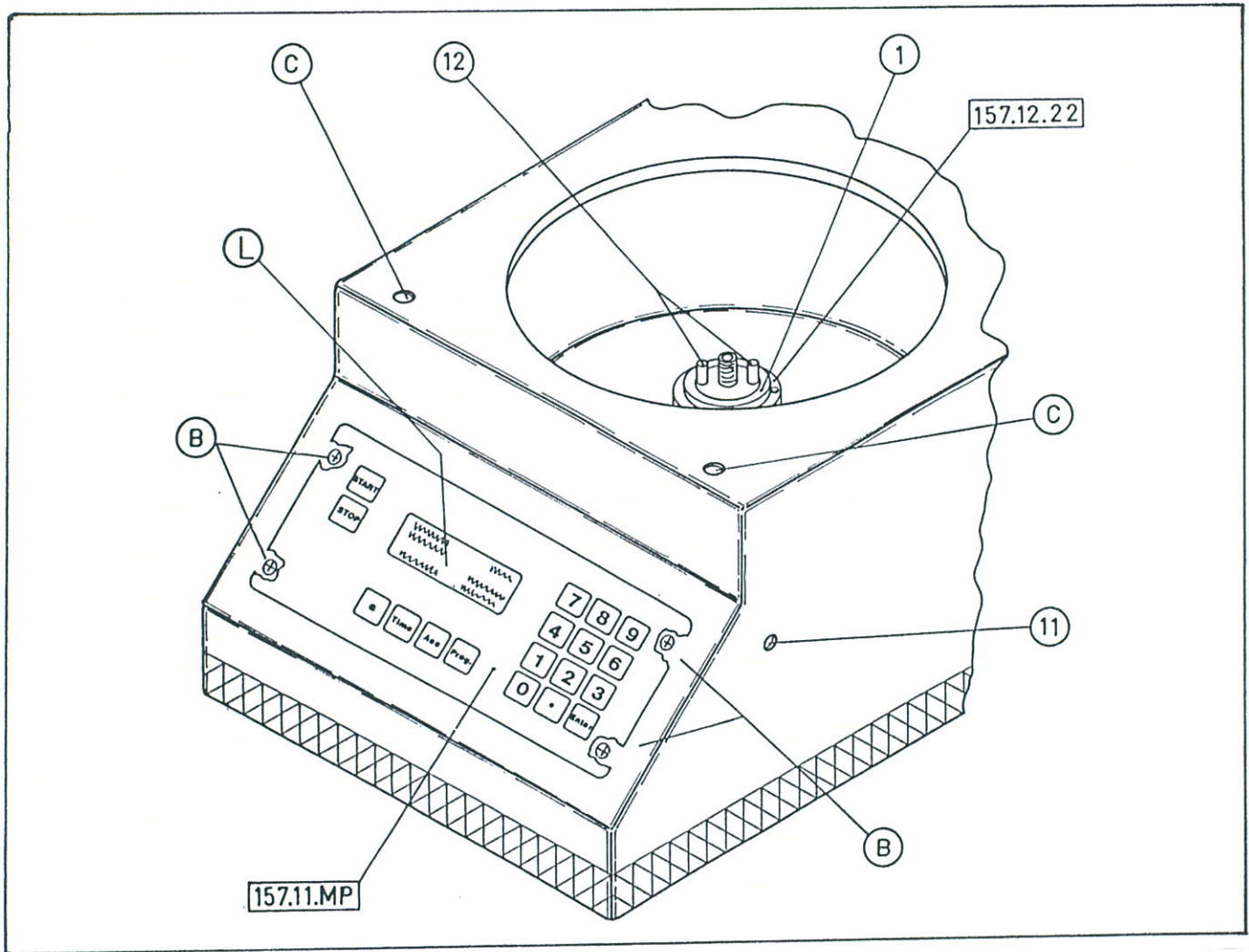

Fig. 2

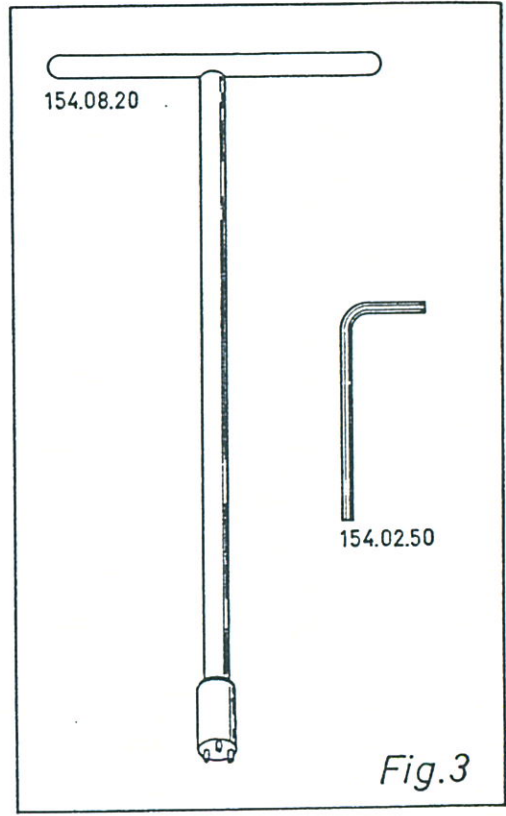
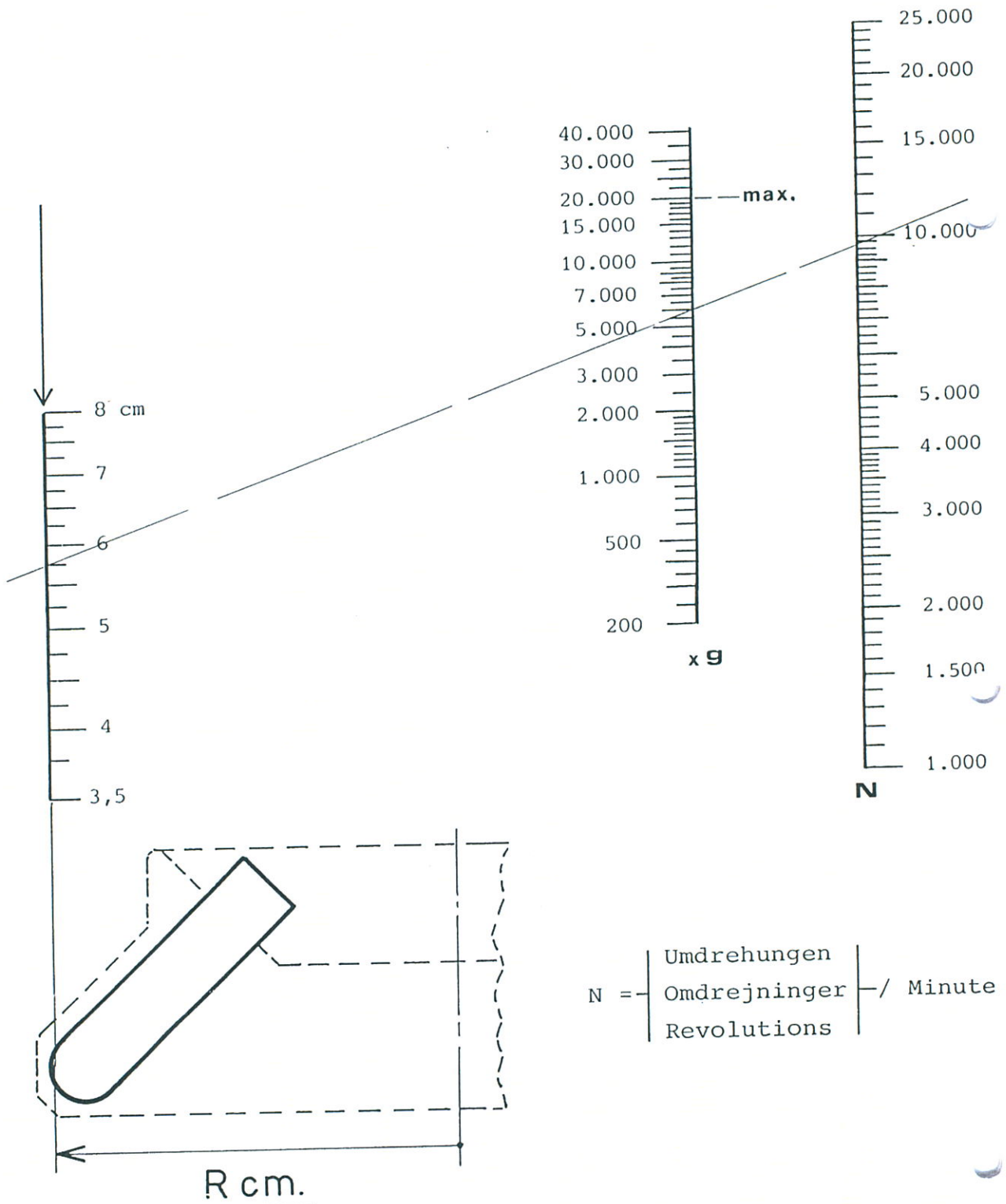

Fig. 3

$$g = 11,18 \times R(\text{cm}) \times N^2 \times 10^{-6}$$



$N = \left\{ \begin{array}{l} \text{Umdrehungen} \\ \text{Omdrejninger} \\ \text{Revolutions} \end{array} \right\} / \text{Minute}$

ROTORS

A wide selection of standard inserts of glass, polypropylene, polystyrol etc. are available for the Ole Dich High-Speed centrifuges.

For the most popular inserts, we have a large programme of standard rotors, as shown on the following page. The type, number and ordering information is listed on the table opposite together with associated inserts. All rotors are manufactured to a high degree of precision in anodized aluminium. The rotors are therefore built to tolerate washing in quite ordinary laboratory detergents.

ANGLE ROTOR



SPECIAL ROTORS

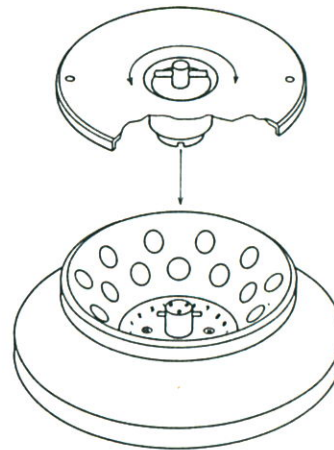

SWING-OUT ROTOR

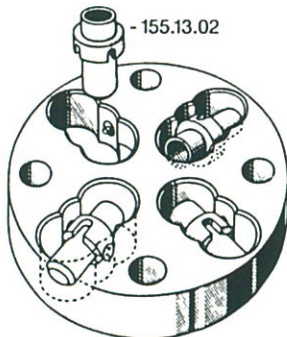

The Swing-out ROTOR type 157.120.U is available with 4 type 155.13.02 holders for type "H" inserts.

Special accessories can be provided upon request, for example:

- Rotors for special inserts.
- Reduction inserts (adaptors).
- Combi-rotors.
- Rotor-covers.

ALTERNATIVE MODELS

MICROCENTRIFUGE 155



Max. G-value: 18.000 g
 Max. RPM: 20.000 RPM
 Mechanical time switch 0-4 or 0-15 min.
 Braking time 18.000 - 0 g: 5-10 secs.
 Rotation controlled cover lock
 Max. No. of samples: 6x4 ml / 16x0,4 ml

BLOOD CENTRIFUGE

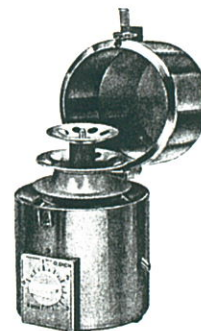



Type 158.SL.04: 3.000 RPM / 500 x g
 Type 158.SLB.04: 1.100/3.000 RPM 70/500 x g
 Timer: 0-4 min.
 10 tubes Ø 10x75-100 mm
 Material: stainless steel

INSERTS

ROTORS

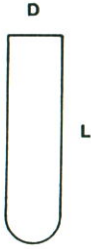
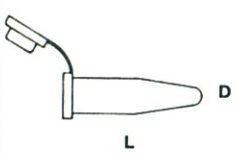
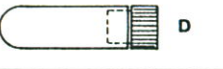
Rotor types marked *** cannot be used in COOLING CENTRIFUGE type 157.MP.RF.

TYPE	Ø D×L mm	ml	MATERIAL						R cm	G.max MP.	G.max MP.RF.	CAPACITY SLIDE ROTOR ANGLE ROTOR	TYPE
			POLYPROPYLENE	POLYSTYROL	GLASS								
	A	8×30	0,5	●				12	●	4,4	30.000	30.000	157.099.A
	B	10×30	1	●				10	●	4,5	30.000	30.000	157.099.B
	B2	9×50	1,5	●				20	●	6,1	15.000		*** 157.150.B2
	C	12×35	2	●				6	●	4,3	30.000	30.000	157.099.C
	E	13×50	4					6	●	5,3	30.000	30.000	157.120.E
								12	●	6,7	20.000	20.000	157.140.E
	F	11×70	3,5		●			10	●	7,2	15.000		*** 157.150.F
	G	10×75	3,9	●				8	●	7,2	15.000		*** 157.150.G
	H	12,5×38	2,5			●		6	●	4,4	30.000	30.000	157.099.H
	L	7×50	0,8					16	●	5,3	30.000	30.000	157.119.L
	M	8,2×41	1			●		12	●	4,9	30.000	30.000	157.105.M
	O	16×65	6			●		6	●	6,5	15.000	20.000	157.137.O
	R	11×56	3			●		6	●	5,6	30.000	30.000	157.119.R
	T	13×75	7		●			8	●	7,2	15.000		*** 157.150.T
	X	17×67	10		●			6	●	6,5	15.000	20.000	157.139.X
Z	20×47	8,5			●		8	●	6,3	15.000	20.000	157.135.Z	
01	8×45	0,8			●		24	●	6,1	20.000		*** 157.145.01	
02	25×55	14			●		6		6,6	10.000	15.000	157.140.02	
	D	10,8×39	1,5				8	●	5,0	30.000	30.000	157.110.D	
							12	●	6,2	20.000	30.000	157.130.D	
							20	●	5,4	15.000	20.000	157.137.D	
							24	●	6,1	15.000		*** 157.150.D	
P	7,8×30	0,75					12	●	4,3	30.000	30.000	157.099.P	
							24	●	5,1	20.000	30.000	157.127.P	
K	5,8×29	0,25					16	●	5,0	30.000	30.000	157.119.N	
S	5,8×47,5	0,4					16	●	5,5	30.000	30.000	157.119.N	
N	5,8×47,5	0,45					16	●	5,5	30.000	30.000	157.119.N	
	W	13×46	2				6	●	5,3	30.000	30.000	157.120.E	
							12	●	6,7	20.000	20.000	157.140.E	
	I	11×45					6	●	4,7	20.000	30.000	157.114.I	
							12	●	6,1	20.000	20.000	157.140.I	

	∅ D x L mm	ml.	MATERIALE	LEVERANDØR	ORDRE NR.
A	8 x 30	0,5	GLAS	OLE DICH	A/8 x 30
B	10 x 30	1	GLAS	OLE DICH	B/10 x 30
B2	9 x 30	1,5	GLAS	OLE DICH	B2/9 x 50
C	12 x 35	2	GLAS	OLE DICH	C/12 x 35
D	10,8 x 39	1,5	POLYPROPYLEN	SARSTEDT	72.690
E	13 x 50	4	POLYPROPYLEN	NUNC	341 378
			POLYSTYREN	NUNC	361 239
F	11 x 70	3,5	POLYETHYLEN	NUNC	466 982
G	10 x 75	3,9	POLYSTYREN	SARSTEDT	55.480
H	12,5 x 38	2,5	POLYPROPYLEN	NUNC	349 638
I			F.EKS.	SARSTEDT	CB.300
K	5,8 x 29	0,25	POLYETHYLEN	MILIAN INSTRUMENTS	ETH-26
L	7 x 50	0,8	POLYSTYREN	SPEC. HOLLAND	
M	8,2 x 41	1	POLYPROPYLEN	MILIAN INSTRUMENT	
N	5,8 x 47,5	0,55	POLYPROPYLEN	MILIAN INSTRUMENT	PAT-22
O	15 x 65	6	POLYSTYREN	NUNC	341 440
P	7,8 x 30	0,75	POLYPROPYLEN	SARSTEDT	72.699
R	11 x 56	3	POLYSTYREN	ELLERMANN	
S	5,8 x 47,5	0,4	POLYPROPYLEN	MILIAN INSTRUMENT	PRO-22
			POLYETHYLEN	MILIAN INSTRUMENT	EET-23
			POLYETHYLEN	SARSTEDT	72.700
			POLYPROPYLEN	SARSTEDT	72.701
T	13 x 75	7	POLYPROPYLEN	SARSTEDT	55.525
			POLYSTYREN	SARSTEDT	55.475
W	13 x 46	2	POLYPROPYLEN	NUNC	341 173
X	16,8 x 67	10	POLYPROPYLEN	SARSTEDT	55.533
			POLYSTYREN	SARSTEDT	55.481
Z	20 x 47	8,5	POLYPROPYLEN	SPEC. BELGIEN	
01	8 x 45	0,8	POLYPROPYLEN	MILIAN INSTRUMENT	
02	25 x 55	14	POLYPROPYLEN	OLE DICH	01/25 x 55